

THE ARMENIAN TRADITIONAL CHURCH AND ITS SYMBOLISM

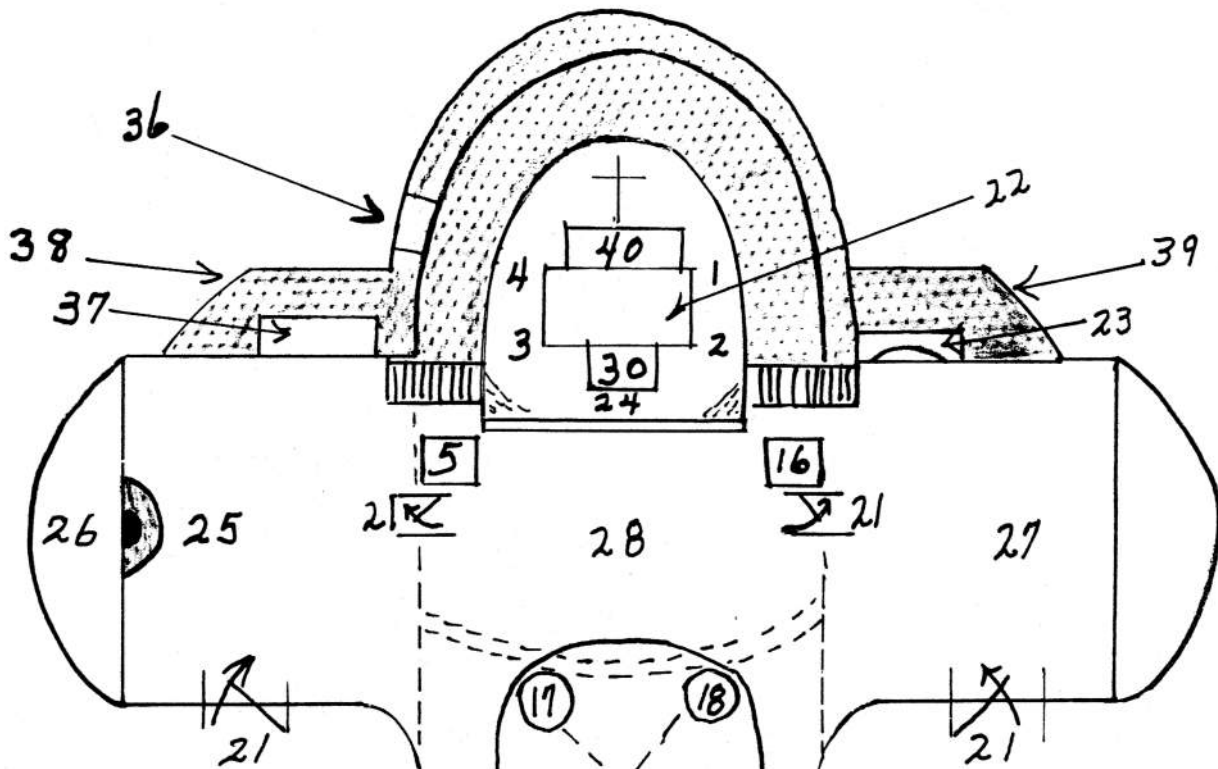

1. St. Matthew
2. St. Mark
3. St. Luke
4. St. John
(the 4 pillars on the Khoran)
5. St. Peter
6. St. Antreas (Andrew)
7. St. Philip
8. Krikor Lusavorich
9. Simon Gananzee
(the Canaanite)
10. St. Bartholomew
11. Thaddeus
12. Madathia
13. Hagopos Alpia (James)
14. Thomas
15. Hagopos Ghepeos
16. Paul (Boghos)
17. The four pillars
18. upon which rests
19. the Gatoghigue
20. (the 4 Gospels)
21. The 5 doors

22. Avak Khoran
23. Left side Khoran
24. PEM, - Pulpit
25. Baharan - right side,
(chapel or vestry)
26. Avazan - Baptismal font
27. Left side Vestry
28. TAS - Chancel
29. Court - Adyan
30. Badvantan
31. Entrance
32. Kavit - right side
34. Kavit - left side
35. Main Western Door
36. Khor-hur-ta-notz-
(chamber) Undzayanan
37. Right side Khoran
38. Small rooms for
39. vessels, books, etc.,
and may be used for
confession also.
40. Picture - Holy Virgin and
Child

THE PLAN

